

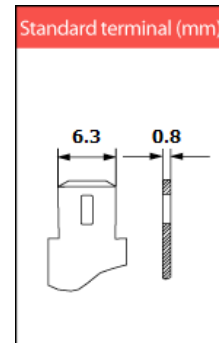

Battery for multi purpose use

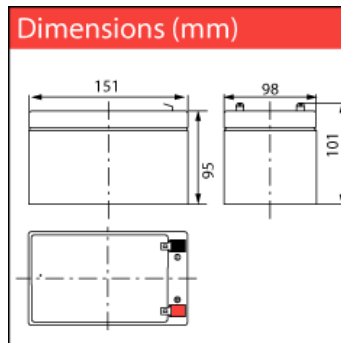

Nominal voltage	12 V	
Nominal Capacity (20HR,20°C):	12 Ah	
Internal resistance	Approx. 19 m Ω	
Maximum charging current	3.6 A	
Maximum discharge current	180 A (5 sec.)	
Operating temperature range	-20°C ~ 50°C	
Float use/ cycle use	13.6 – 13.8V/ 14.5 – 14.9V	
Expected life (20°C)	3 – 5 years in float charge	
Standard terminal	Faston 6.3 mm	
Housing material	ABS	
Dimensions	length	151 mm
	width	98 mm
	height	101 mm (±1 mm)
Approx. Weight	3.56 kg	
Packing	4 pcs/box	

- Typical applications:**
- Alarm devices
 - Measuring equipment
 - Emergency lighting
 - Medical equipment
 - Telecommunication systems
 - UPS systems
 - Toys
 - Domestic applications.

- Valve Regulated Maintenance Free
- High current drain grid being resistant to corrosion by virtue of a lead-calcium alloy
- Absorbent Glassmat Technology (AGM)
- Classified as non- spillable and Non Dangerous goods by IATA, FAA, ADR, IMDG
- Can be discharged or stored in any position without leakage
- Cannot be charged while the terminal is downward

Constant Current Discharge Characteristics (A, 20°C)									
F.V/TIME	5min	10min	15min	30min	60min	3h	5h	10h	20h
9.60V	46.0	31.0	24.5	13.5	7.80	3.17	2.08	1.12	0.60
10.2V	43.7	29.5	23.5	13.0	7.49	3.12	2.05	1.11	0.59
10.8V	41.0	27.7	22.3	12.3	7.11	3.06	2.01	1.10	0.59

Constant Power Discharge Characteristics (Watt, 20°C)									
F.V/TIME	5min	10min	15min	30min	60min	3h	5h	10h	20h
9.60V	513	350	279	155	90.3	37.6	25.0	13.4	7.20
10.2V	488	332	268	149	86.7	37.1	24.5	13.3	7.10
10.8V	458	312	255	141	82.4	36.3	24.0	13.3	7.10

Charging characteristics

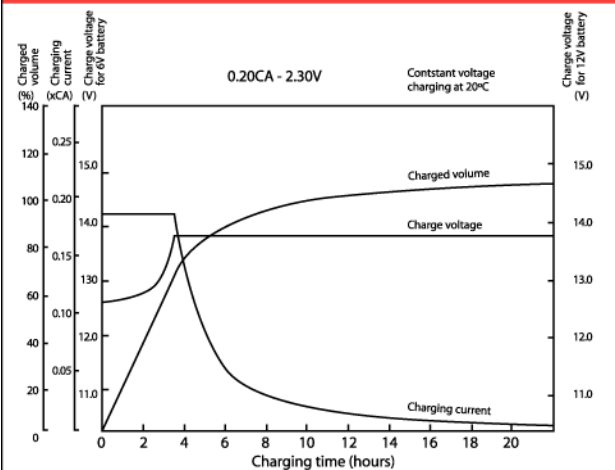

Discharge characteristics curves

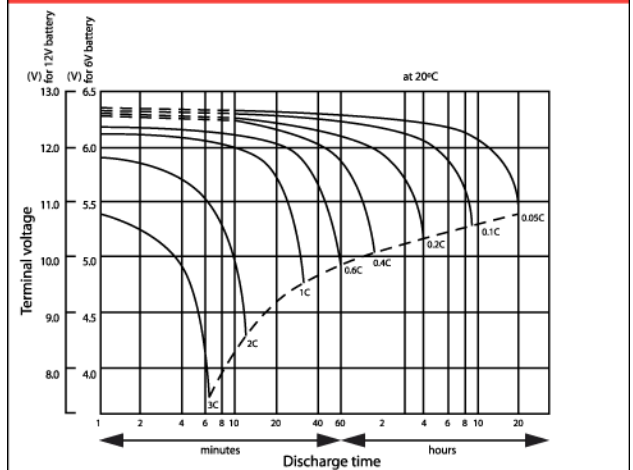

Relationship between charging voltage and temperature

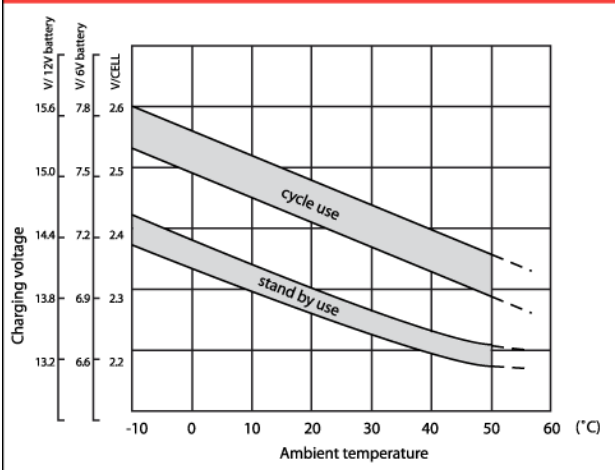

Cycle service life in relation to depth and discharge

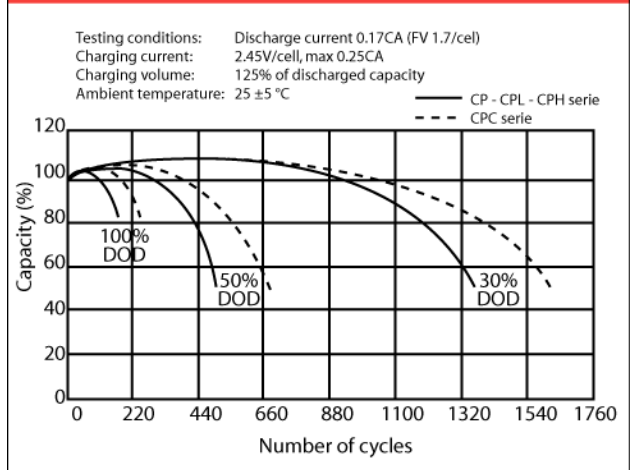

Models available

Model	capacity (Ah)	Dimensions (mm)	weight
CP 1.2 - 6	1.2	97 x 24 x 58	0.30 kg
CP 3.2 - 6	3.2	134 x 34 x 66	0.67 kg
CP 3.5 - 6	3.5	194 x 25 x 56	0.58 kg
CP 4 - 6	4	70 x 47 x 107	0.68 kg
CP 7 - 6	7	151 x 34 x 100	1.12 kg
CP 12 - 6	12	151 x 50 x 100	1.92 kg
CP 12 - 6L	12	151 x 50 x 100	1.92 kg
CP 0.8 - 12	0.8	96 x 25 x 62	0.36 kg
CP 1.2 - 12	1.2	97 x 43 x 58	0.56 kg
CP 2 - 12M	2	150 x 20 x 90	0.68 kg
CP 2.1 - 12	2.1	178 x 35 x 67	0.94 kg
CP 2.3 - 12C	2.3	182 x 24 x 62	0.76 kg
CP 2.9 - 12	2.9	79 x 56 x 105	1.08 kg
CP 3.2 - 12	3.2	134 x 67 x 67	1.32 kg
CP 4.5 - 12	4.5	195 x 47 x 74	1.6 kg
CP 5 - 12	5	90 x 70 x 107	1.98 kg
CP 7 - 12	7	151 x 65 x 97.5	2.52 kg
CP 7 - 12 L	7	151 x 65 x 97.5	2.56 kg
CP 12 - 12	12	151 x 98 x 101	3.56 kg
CP 17 - 12I	17	181 x 77 x 167	5.74 kg
CP 20 - 12B	20	181 x 77 x 167	6.00 kg
CP 24 - 12I	24	166 x 175 x 125	7.88 kg
CP 38 - 12I	38	197 x 165 x 170	12.96 kg
CP 65 - 12I	65	348 x 167 x 178	22 kg

VdS approved VRLA batteries:

The VdS-approved Cellpower batteries form a special range that has been tested and qualified by the German VdS institute. The concept behind VdS recognition; ensuring tested and certified quality in the products and services being offered in the safety and security markets, is of equally advantageous for user and supplier.

Safety and security systems are approved by the VdS and monitored in subsequent use to protect property and life and help to keep a insurance premiums lower.

Apart from the VdS approval, this range is also approved by the Dutch NCP institute, further underlining the high quality of this range.

Typical applications:

- VdS & NCP approved alarm systems
- Fire & burglar alarm systems